

## AQUARIUS

# Corrosion Coupon Racks

Corrosion Coupon Racks  
for the determination of  
Corrosivity of Water  
by evaluation of Pitting  
and by Weight Loss on  
Flat Metal Specimens



- √ For 80 x 13 x 1.6 mm Flat Specimens
- √ Rated to 1000 kPa. @ 50 °C Max. in PVC or
- √ Rated to 1000 kPa. @ 100 °C Max. in MS
- √ Models for 4 Coupons
- √ Models for 2 Coupons
- √ Velocities of 0.5 - 2.00 m/s.
- √ Similar to ASTM rack
- √ PVC Backing Board
- √ With or Without Isolation Valves

### Model - CCRACK522

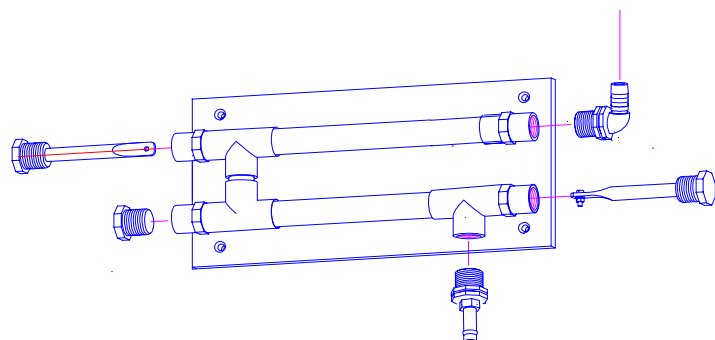

## TECHNOLOGY FOR THE YEAR 2001 AND BEYOND

# Aquarius Corrosion Coupon Racks

The **Aquarius Corrosion coupon exposure racks** are designed to retain the coupons in the laminar flow region and away from the turbulent flow areas around the Tee sections. The velocity across the coupons can be controlled via the isolation valves to represent flow conditions and velocities in heat exchangers.

Properly prepared and pre-weighted coupons or specimens of the metal of interest and approx. 75 - 80 mm in length and 13 mm width, and 1 - 2 mm thick are attached to the coupon holder via plastic screws and retaining nuts and the coupon holder screwed into the pipe rack, the specimen being held in the centre of the flowing stream and free from all but flowing debris.

As the pipe internal diameter is 22.5 mm the velocity across the specimens can be calculated by measuring the litres per minute flow through the rig with the coupons fitted.

## **Flow Rate Lts./min.    Velocity m/sec**

5.92 .....	0.25
11.84 .....	0.50
23.68 .....	1.00
35.52 .....	1.50

or **Its/min. Flow / 23.68 = Metres/second velocity**

Changes in thickness from the 2 mm thick specimens in the calculations above, to 1.0 mm thick, reduce the velocity by only 2.5% and in most cases can be ignored, or the flow rate readjusted.

System pressure should remain constant to maintain the desired velocity, or if velocity is set similar to the heat exchanger velocity then any variance in pressure and change in velocity is experienced by both and is indicative of corrosion rates under actual operating conditions.

For more information refer to **ASTM D2688 - Standard Test Methods for Corrosivity of Water in the Absence of Heat Transfer (Weight Loss Methods)**

**Units are supplied WITHOUT the actual metal specimens.**

## **MODELS AVAILABLE**

**Model - CCRACK2 = With 2 coupon holders and two 15 mm plugs + inlet & outlet valves. Rated to 1000kPa pressure and 50°C. Manufactured using PVC pipe and fittings. Coupon holders constructed from PVC rod.**

**Model - CCRACK4 = With Four Coupon Holders + inlet and outlet valves. Rated to 1000kPa pressure and 50°C. Manufactured using PVC pipe and fittings. Coupon holders constructed from PVC rod.**

**Model - CCRACK2M = With 2 coupon holders and two 15 mm plugs without any valves. Rated to 1000kPa pressure and 50°C. Manufactured using PVC pipe and fittings. Coupon holders constructed from PVC rod.**

**Model - CCRACK522 = With 2 coupon holders designed to fit below an AT522 controller. Rated to 1000kPa pressure and 50°C. Manufactured using PVC pipe and fittings. Coupon holders constructed from PVC rod.**

**Model - CCRACK2/HP = With 2 coupon holders and two 15 mm plugs + inlet & outlet valves. Rated to 1000kPa pressure and 100°C. Manufactured using Galvanised steel pipe and fittings. Coupon holders constructed from Glass filled Teflon rod.**

# Aquarius Corrosion Coupon Racks

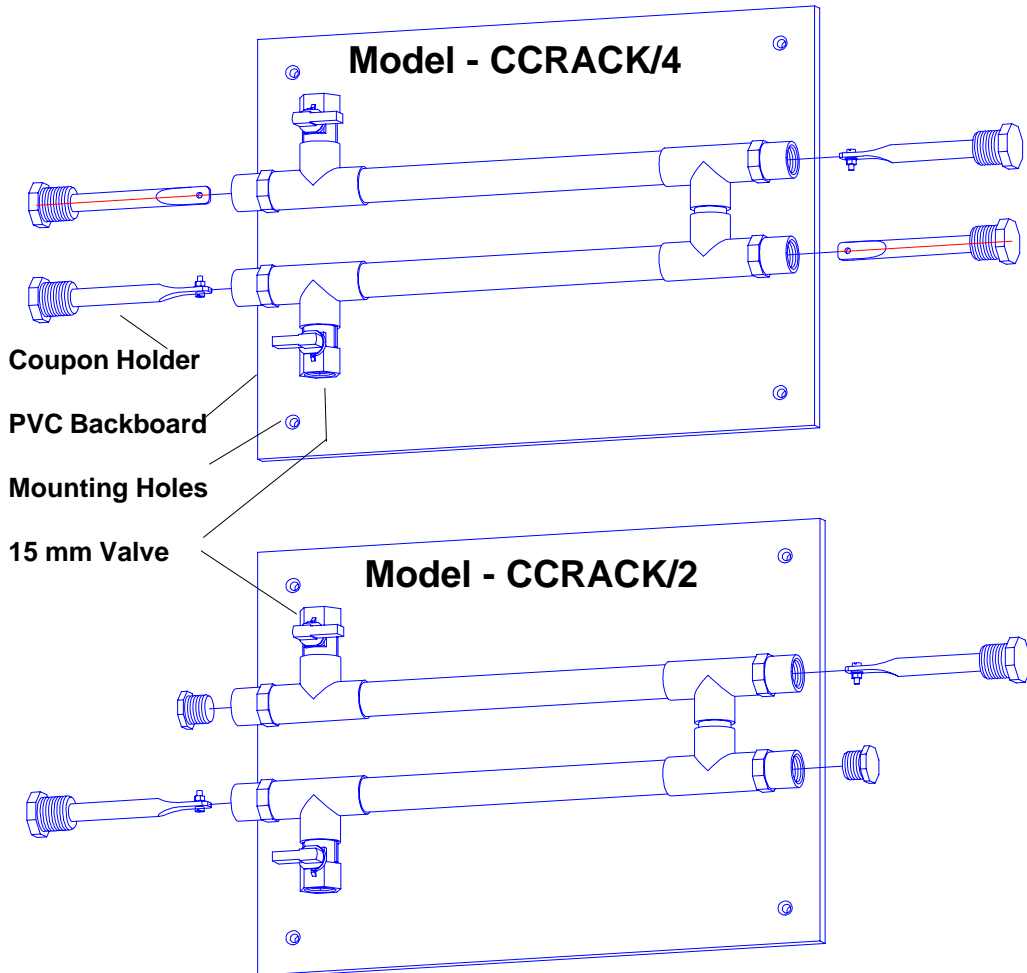

# Aquarius Corrosion Coupon Racks

## MANUFACTURER'S PRODUCT WARRANTY

**AQUARIUS TECHNOLOGIES PTY LTD.** manufactures a range of equipment under a Quality Assurance system to ISO9001:1994 standards and warrants equipment of its manufacture to be free of defects in material or workmanship.

Liability under this policy extends for 12 months from the date of installation, or 24 months from the date of shipment from our factory, whichever ever occurs first. The manufacturer's liability is limited to repair or replacement of any failed equipment or part of, which is proven to be defective in material or workmanship upon the manufacturer's examination. This warranty does not include removal or installation costs and in no event shall the manufacturer's liability exceed its selling price of such equipment or part.

Aquarius Technologies Pty Ltd. disclaims all liability for damage to its products through improper installation, maintenance, use or attempts to operate such products beyond their functional capacity, intentionally or otherwise, or any unauthorised repair. Aquarius Technologies Pty Ltd. will not be responsible for any consequential or other damages, injuries, or expense incurred through use of its products.

This warranty is in lieu of any other warranty, either expressed or implied. Aquarius Technologies Pty Ltd. make no warranty of fitness or merchantability. No agent of ours is authorised to provide any warranty other than above.

This warranty does not exclude any condition or warranty implied by the Trade Practices Act 1974 or separate State Laws in Australia and is in addition to any other right that the original purchaser or any subsequent purchaser may have under Australian law.

Should a unit fail to function normally, please contact our Customer Service Department by phone or fax quoting, Model Number, and Serial Number, for initial discussion of the problems encountered, and if it is necessary to return the item to the factory, a Return Authorisation number will be given to facilitate return, and repair or replacement of the item.

The item for return should be carefully packaged to prevent any damage in transit, contain the Return Authorisation identification number, customer identification, and return delivery details, and the freight prepaid to our factory. If in the opinion of our factory, after examination, the failure was due to materials or workmanship, repair or replacement will be made without charge for parts, labour and return freight. A reasonable service charge will be made for diagnosis and/or repairs due to normal wear, abuse, tampering or damage in transit.

**AQUARIUS TECHNOLOGIES PTY Ltd.** reserve the right to continue development and improvement of the entire range of our equipment, and therefore minor changes may occur due to these improvements and the continuing development.